

CURRENT-SENSORLESS METHOD FOR SPEED CONTROL OF INDUCTION MOTOR BASED ON HYSTERESIS PULSE WIDTH MODULATION TECHNIQUE

Cuong Dinh TRAN^{1,2,*}, Pavel BRANDSTETTER². Bach Hoang DINH¹, Sang Dang HO^{1,2}, Minh Chau Huu NGUYEN²

¹Faculty of Electrical and Electronics Engineering, Ton Duc Thang University, Ho Chi Minh City, Vietnam

²Faculty of Electrical Engineering and Computer Science, VSB-Technical University of Ostrava, Czech Republic

*Corresponding Author: Cuong Dinh Tran (email: trandinhcuong@tdtu.edu.vn)
(Received: 18-November-2018; accepted: 21-January-2019; published:25-January-2019)
DOI: <http://dx.doi.org/10.25073/jaec.201824.213>

Abstract. This paper describes a new solution to control the induction motor drive system without current sensors based on improving the Hysteresis Pulse Width Modulation technique. It has proposed a control scheme which uses stator currents estimated from the differential equation of state variables to replace the feedback signal from current sensors applied in the hysteresis current controller. To verify the proposed method, simulations in MATLAB/Simulink have been implemented in various operating conditions of the motor where its speed has been changed under load as well as no load conditions. The simulation results have demonstrated the effectiveness of the proposed control method for inductive motor drives.

Keywords

current sensorless, estimated stator currents, field-oriented control, hysteresis controller, induction motor.

NOMENCLATURE

Ψ_S^S	Stator flux vector in $[\alpha, \beta]$ coordinate system
Ψ_R^S	Rotor flux vector in $[\alpha, \beta]$ coordinate system
i_S^S	Stator current vector in $[\alpha, \beta]$ coordinate system
i_R^S	Rotor current vector in $[\alpha, \beta]$ coordinate system
u_S^S	Stator voltage vector in $[\alpha, \beta]$ coordinate system
$u_{S\alpha}, u_{S\beta}$	Stator voltage component in $[\alpha, \beta]$ system
u_{Sx}, u_{Sy}	Stator voltage component in $[x, y]$ system
u_a, u_b, u_c	Stator voltage component in $[a, b, c]$ system
i_{Sx}	Flux current component
i_{Sy}	Torque current component
R_S, R_R	Stator and rotor resistance
L_S, L_R	Stator and rotor induction
L_m	Magnetizing induction
T_R	Rotor time constant
ω_m	Mechanical angular speed
p	Pole pair number
ψ_R	Nominal rotor flux
γ	rotor flux angle

1. INTRODUCTION

The induction motors (IM) are the most popular machine applied in industrial applications due to their simple and rugged constructions, high reliability, low cost with various applications. Nowadays, the development of power electronics and modern control techniques provides excellent control capabilities for the IM drives [1].

Scalar control and vector control (VC) are two main approaches to control speed and torque in IM drive system. The voltage per hertz constant method, which is the most popular of Scalar control technique, is based on varying the voltage and the frequency to control the torque and the speed of IM. Advantages of this method are low cost, simplicity, no need the feedback signals of the sensors. However, the torque of IM cannot be control exactly that is the major disadvantage of the scalar method [2]. The field-oriented control (FOC) is the most typical method of VC techniques. In FOC strategy, the stator current space vectors are decomposed into two perpendicular elements: i_{sx} and i_{sy} . As a result, the torque and the rotor flux can be independently controlled as the same as the controllers of separated excited DC motors. The disadvantage of FOC strategy is that the control method with the mathematical model of IM has more complex than the scalar control methods. However, both the torque and speed of IM can be controlled exactly at the same time. Therefore, FOC method is applied in complex control applications in the industrial field [2-4].

In the control model based on FOC technique, the controller needs the feedback signal from sensors, such as rotor speed, stator currents, and voltages. Obviously, the quality of the sensor's signals has affected the performance of the controlled IM drive systems. Especially, the signals of stator currents play a vital role throughout all stages of the control algorithms. Thus, if there is any unexpected occurrence of those current sensors, it causes the improper operation in the IM drives. So, to enhance the performance of the IM drives during such abnormal situation, it needs to detect and isolate the faulty sensor's signal as well as reconfigure the controller schemes to

adapt to the new situation. It is called the sensorless control approach [5, 6] to deal with the lack of sensor signals in the controller schemes. When the controller scheme of IM drives uses three current sensors if one single sensor is broken, the estimated signal of that such faulty sensor can be easily obtained by Kirchhoff's law [7]. However, in the control scheme using two current sensors, when one sensor is broken, the loss signal cannot be estimated from Kirchhoff's law and the current sensorless strategy thus is the appropriate choice [8]. A current sensorless approach of IM's controllers based on the FOC method and PI was proposed by using the stator current's values estimated from the rotor speed, DC voltage and DC link current of the inverter [8]. The simulation results demonstrated the suitability of this method, however, there was still high ripple of the actual speed at high-speed ranges. In [9], authors introduced the method of "Indirect FOC vector control without current sensors" as a solution for Fault Tolerant Control in IM drive system. It replaced the classical hysteresis current controller by the space vector modulation technique with only a feedback signal of the rotor speed. It showed the good performance in the simulation, however, there were some ripples for torque responses of the IM drive system. Similarly, a current sensorless speed controller based on a stator voltage scalar and a feedback signal of the speed sensor has been presented in [10]. The advantage of this method was simpler and faster than the FOC method, however, the speed responses were still disturbed in the torque control of the IM drives.

The stator current estimation method from the voltage and the rotor speed signals is applied to detect the current sensor fault in the fault-tolerant control technique of IM drive systems [11]. In this paper, another application of the stator current estimation technique is proposed with the current sensorless strategy for the speed controller of IM drives based on the hysteresis current method where actual current signals are replaced by the estimated stator currents in the comparator of the hysteresis current controller. The performance of the proposed method will be verified by simulations in MATLAB/Simulink. The paper's structure is consists of 4 parts where the first section is the

introduction and the second describes the main ideas of applying the sensorless control scheme, the simulation results then are demonstrated in section 3 and the conclusion finally is stated in the fourth one.

2. THE CURRENT SENSORLESS STRATEGY FOR SPEED CONTROL

In this section, the typical FOC method using current sensors and without current sensors will be described.

2.1. The Field Oriented Control Technique base on hysteresis current controller

The Field Oriented Control (FOC) is a popular control method used in the IM drive systems where the torque and the flux are controlled independently. The stator current space vector is decomposed into two perpendicular elements, i_{sx} , and i_{sy} , in the rotating reference frame [x,y] corresponding to the rotor flux space vector orientation to the x-axis as shown in Fig.1. In this way, the component i_{sx} is controlled to maintain the amplitude of the flux rotor at the reference value. As a result, we can control the torque in the linear relationship with component i_{sy} [3].

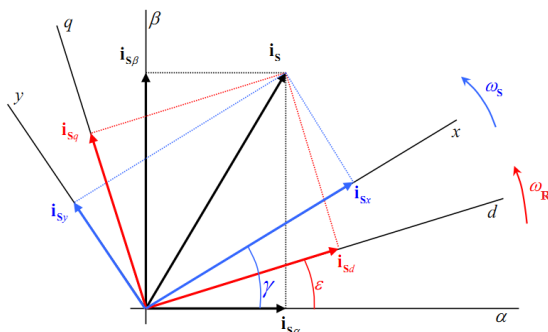

Fig. 1: Vector diagram of the induction motor – the principle of vector control.

The Space Vector Pulse Width Modulation (SVPWM) and the Hysteresis Pulse Width Modulation (HPWM) are two main methods in the FOC. The SVPWM technique controls the switching on the inverter by space voltage vector. The SVPWM is one of the most powerful methods, it can maintain a constant motor speed even under unstable load condition with the low ripple. However, the SVPWM requires complicated computing and the transient period is too long in the control. The HPWM technique controls the switching on the inverter by the current controller. The current controller compares the phase current with the reference current for switching on the inverter. The ripple of the HPWM is higher the SVPWM, however, the hysteresis control is simpler, faster and this technique is more suitable with unstable parameters cases [12, 13]. In the paper [13], the hysteresis space vector pulse width modulation (HSVPWM) method is proposed to control the rotor speed of IM drive. This method is a combination between HPWM and SVPWM to control the switching on the inverter. When three methods are compared, the ripple of the current output in HSVPWM method is the smallest. However, due to both HPWM and SVPWM are calculated at the same time, so the algorithm of HSVPWM is the most complex, and the steady time is also longest. In this paper, the HPWM technique will be applied to control the speeds of IM drive.

The IM can be controlled by the FOC technique shown as Fig.2 [13, 14]. The reference electrical torque T_e^* can be obtained from the difference between reference speed and actual speed by PI controller. Then the reference component i_{sy}^* can be calculated as shown in Eq. (1) below

$$i_{sy} = \frac{2}{3p} \cdot \frac{L_R}{L_m} \cdot \frac{T_e}{\psi_R} \tag{1}$$

The reference component i_{sx}^* can be calculated from the nominal rotor flux as

$$\psi_R = \frac{L_m}{1 + T_R} i_{sx} \tag{2}$$

The measured stator current signals from sensors can be transformed to the rotating coordinate system [x, y] by Clarke-Park transforma-

tion as Eq. (3).

$$\begin{aligned} & \begin{bmatrix} i_{Sx} \\ i_{Sy} \end{bmatrix} \\ &= \frac{2}{3} \begin{bmatrix} \cos(\gamma) & \cos(\gamma - 120^\circ) & \cos(\gamma + 120^\circ) \\ -\sin(\gamma) & -\sin(\gamma - 120^\circ) & -\sin(\gamma + 120^\circ) \end{bmatrix} \\ & \times \begin{bmatrix} i_a \\ i_b \\ i_c \end{bmatrix} \end{aligned} \quad (3)$$

The component rotor flux angle γ can be determined from the feedback rotor speed from the speed sensor and the rotor slip as follows:

$$\gamma = \int (p \cdot \omega_m + \omega_{sl}) dt \quad (4)$$

where: $\omega_{sl} = \frac{i_{Sy}}{T_R \psi_R}$.

In the current controller, actual current values will be compared to the reference currents, then, their error is used to generate switching commands for the inverter to achieve the desired speed of the rotor [ref].

2.2. The Field Oriented Control Technique based on hysteresis current controller without current sensors.

In Fig.3, a sensorless control scheme is introduced where the feedback signals from the current sensors will be replaced by the stator currents from the estimator.

The inputs of the stator current estimator comprise the rotor speed ω_m from the encoder and the stator voltages where these three-phase voltages [u_a, u_b, u_c] will be transformed to the two-phase α - β stationary coordinate system by Clarke transformation as Eq. (5) below.

$$\begin{bmatrix} u_\alpha \\ u_\beta \end{bmatrix} = \begin{bmatrix} \frac{2}{3} & -\frac{1}{3} & -\frac{1}{3} \\ 0 & \frac{1}{\sqrt{3}} & -\frac{1}{\sqrt{3}} \end{bmatrix} \begin{bmatrix} u_a \\ u_b \\ u_c \end{bmatrix} \quad (5)$$

The dynamic model of an induction motor in the α - β coordinate system can be described as

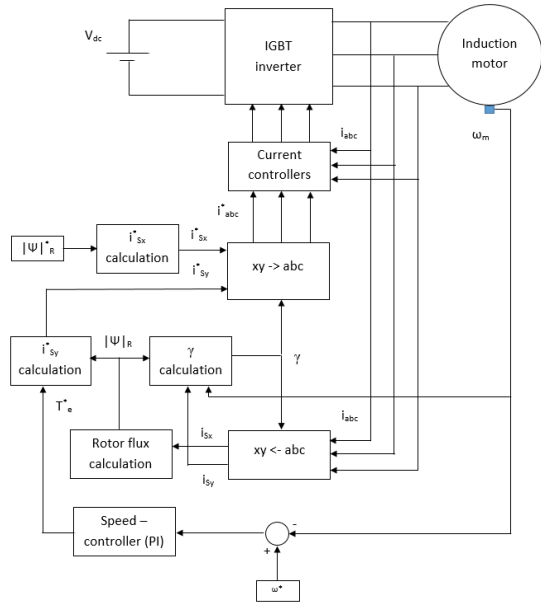

Fig. 2: Block diagram of the HPWM technique with current sensors.

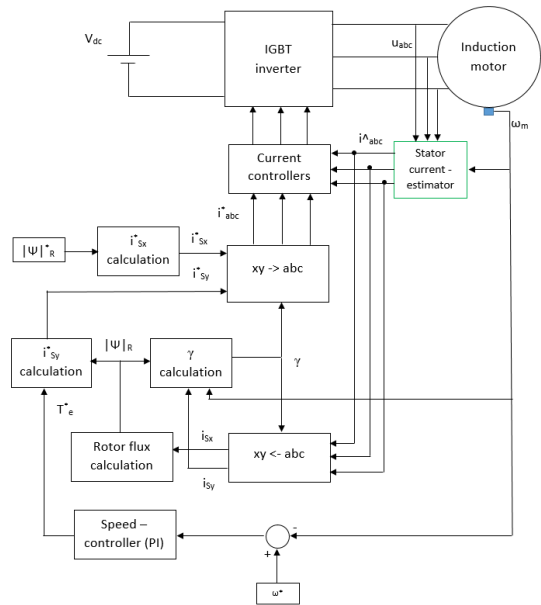

Fig. 3: Block diagram of the HPWM technique without current sensors.

the following expressions:

$$\mathbf{u}_S^S = R_S \mathbf{i}_S^S + \frac{d\mathbf{\Psi}_S^S}{dt} \quad (6)$$

$$0 = R_R \mathbf{i}_R^S + \frac{d\mathbf{\Psi}_R^S}{dt} - jp\omega_m \mathbf{\Psi}_R^S \quad (7)$$

$$\mathbf{\Psi}_S^S = L_S \mathbf{i}_S^S + L_m \mathbf{i}_R^S \quad (8)$$

$$\mathbf{\Psi}_R^S = L_m \mathbf{i}_S^S + L_R \mathbf{i}_R^S \quad (9)$$

From the Eqs (6, 7, 8, 9), we derive the differential equations of the stator and rotor currents in the α - β coordinate system as follows [11]:

$$\frac{di_S^S}{dt} = A[\mathbf{u}_S^S - (R_S + j\frac{L_m^2}{L_R}p\omega_m)\mathbf{i}_S^S + (\frac{L_m R_R}{L_R} - jL_m p\omega_m)\mathbf{i}_R^S] \quad (10)$$

$$\frac{di_R^S}{dt} = A[(\frac{1}{L_S}\mathbf{u}_S^S - (\frac{R_S}{L_S} + jp\omega_m)\mathbf{i}_S^S + (\frac{R_R}{L_m} - j\frac{L_R}{L_m}p\omega_m)\mathbf{i}_R^S] \quad (11)$$

where: $A = \frac{L_R}{L_S L_R - L_m^2}$.

By using the Eqs. (10, 11), finally, we can obtain the estimated stator currents. These estimated stator currents, then, are transformed from the two-phase α - β coordinate system back to the three-phase ABC coordinate system to compare with the reference stator currents. Therefore, the phase currents would be determined with the value around the reference value by the hysteresis tolerance as shown in Fig 4 [12].

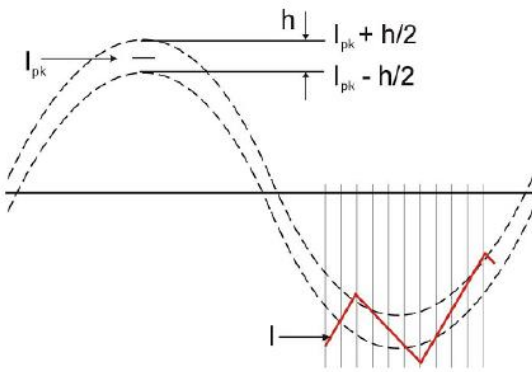

Fig. 4: Shape Wave Flow Control Hysteresis.

As a result, the IM drive system can be controlled to adapt the speed and torque changes by the HPWM technique without current sensors.

3. SIMULATION RESULTS

This section presents the simulation of the speed controller of IM drives based on the

hysteresis current control approach according to the current sensorless method in MATLAB/SIMULINK. The parameters of the investigated system are listed as followings:

$$P_n = 4.0 \text{ kW}, \omega_n = 1430 \text{ rpm}, p = 2.$$

$$I_{Sn} = 8.4 \text{ A}, U_{Sn} = 400 \text{ V}, \Psi_{Sn} = 1.23 \text{ Wb.}$$

$$R_S = 1.405 \Omega, R_R = 1.395 \Omega,$$

$$L_S = 0.178 \text{ H}, L_R = 0.178 \text{ H},$$

$$LL_m = 0.172 \text{ H}, T_R = 0.1276 \text{ s.}$$

Fig.5 describes the scheme of the investigated system including the dynamic model of IM, the PI controller, the current estimator, etc.

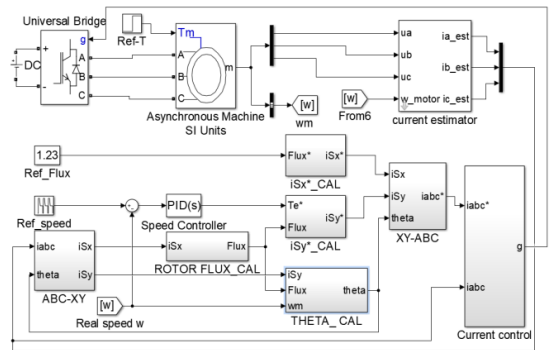

Fig. 5: General Simulink simulation scheme.

Case study 1:

In this first case, the IM has been operated at the normal speed with no load condition. The reference rotor speed starts from zero at $t = 0$ sec. and reaches 50% of the rating value and then, at the time of 2.5 sec., it decreases following the ramp line (2.5 sec.– 3.0 sec.) to 25% of the rating value. The performance of the proposed controller, in this case, is depicted in Fig.6 (a), (b) where the reference speed and actual speed as well as estimated stator currents, are shown. As we can see, the estimated current sharp is slightly rippled due to the characteristics of the hysteresis current method, but, the actual speed is still maintained around the reference values with a small deviation. Due to the symmetric three phase of IM, therefore the comparison between the measured stator current and the estimated stator current simulated with A-phase current is the same in other two phase. The result simulation is shown in

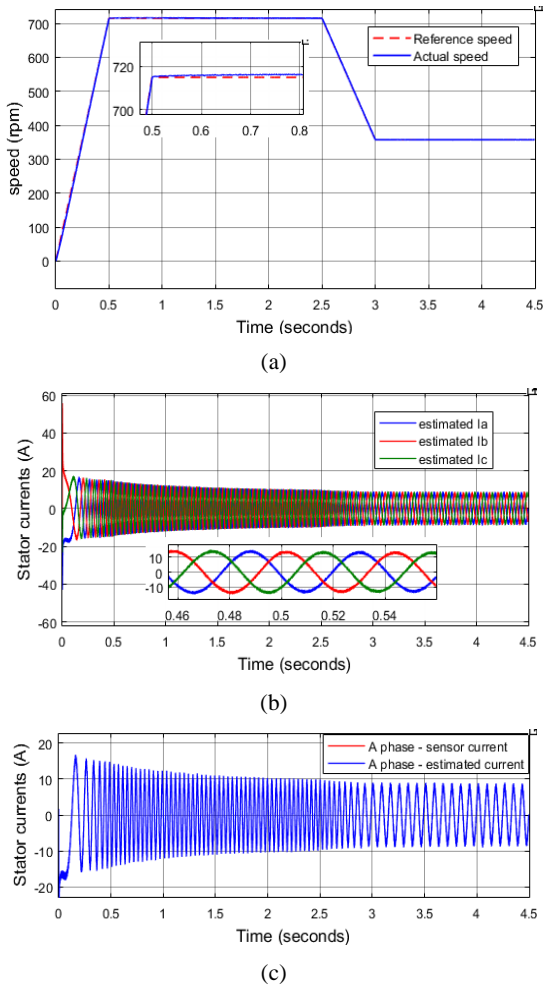

Fig. 6: HPWM technique without current sensors at no load condition: (a) Reference and actual speed at 50% - 25% rating speed, (b) Three phase estimated currents, (c) Comparison between A phase measured current and estimated current.

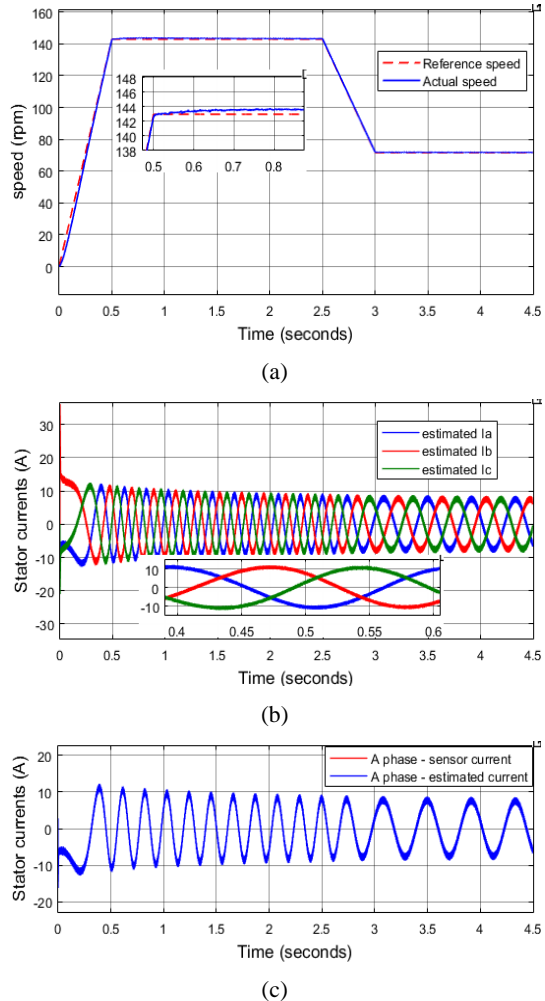

Fig. 7: HPWM technique without current sensors at no load condition: (a) Reference and actual speed at 10% - 5% rating speed, (b) Three phase estimated currents, (c) Comparison between A phase measured current and estimated current.

Fig.6 (c) demonstrates the similarity between the measured current signal and the estimated current signal.

Case study 2:

In this case, the IM has been operated at low speeds with no load condition. Similar to the previous, in this simulation, the reference speed starts from zero at $t = 0$ sec. and reaches 10% of the rating value at 0.5 sec. and then, at 2.5 sec., it goes back to 5% of the rating speed following the ramp line (2.5 sec.– 3.0 sec.). The performance of the proposed controller, in this case, is

depicted in Fig.7 where the reference speed, the actual speed, estimated stator currents as well as the comparison between the measured and estimated current signals are shown. The results show that the controller also works well in the range of low speeds similar to its performance at the normal speed ranges. Therefore, in no load condition, the motor can operate stably with the proposed controller without current sensors.

Case study 3 and 4:

In these two simulations, the speed references have been set up as the same as the references in

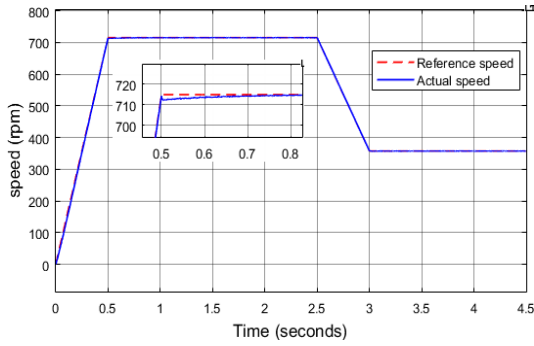

(a)

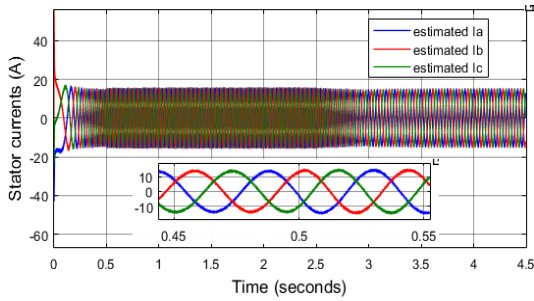

(b)

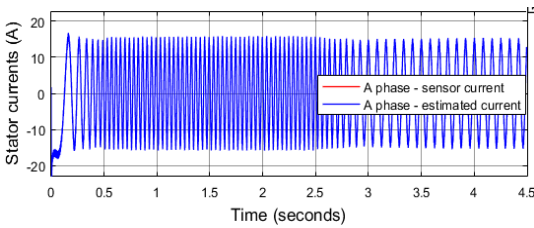

(c)

Fig. 8: HPWM technique without current sensors at 5 (N.m) load torque: (a) Reference and actual speed at 50% - 25% rating speed, (b) Three phase estimated currents, (c) Comparison between A-phase measured current and estimated current.

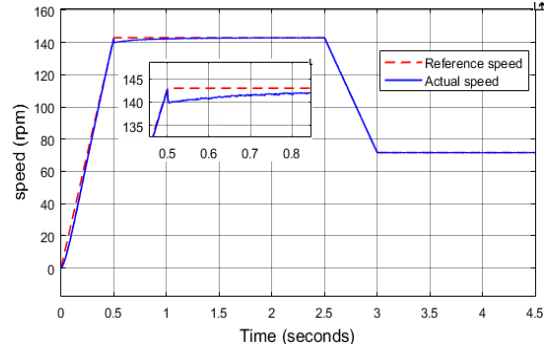

(a)

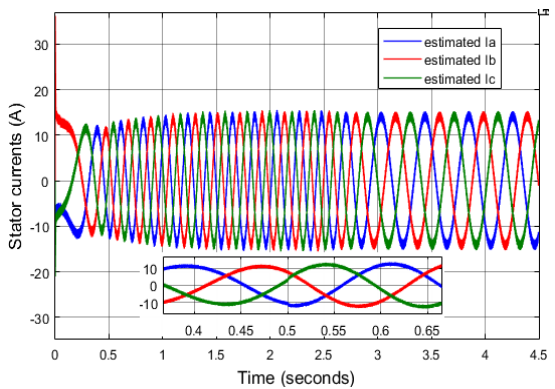

(b)

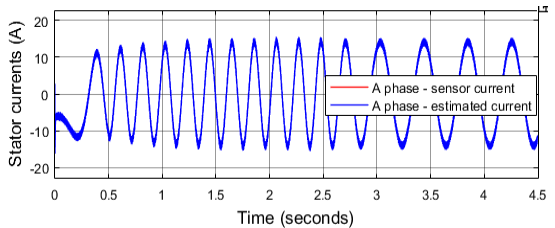

(c)

Fig. 9: HPWM technique without current sensors at 5 (N.m) load torque: (a) Reference and actual speed at 10% - 5% rating speed, (b) Three phase estimated currents, (c) Comparison between A phase measured current and estimated current.

the study case 1 and 2, respectively, but, a constant load torque of 5 (N.m) has been applied during the time of 0.5s. The Fig. 8 and Fig. 9 depict the performance of the current sensorless method in FOC based on HPWM technique of IM drive systems. In Fig. 9, as the same as the previous case, during the low-speed operation there is only a slight overreach in the transient time and later the performance is very good in keeping the speed reference with a small deviation.

Case study 5 and 6:

In the third simulation, the IM has been operated with the reference speeds setting as the same as previous cases, but, a pulse load torque shown in Fig. 10 has been applied during the time of 0.5 sec.

The simulation results depicted in Fig. 11 and Fig. 12 demonstrate clearly that the proposed method based hysteresis current technique with-

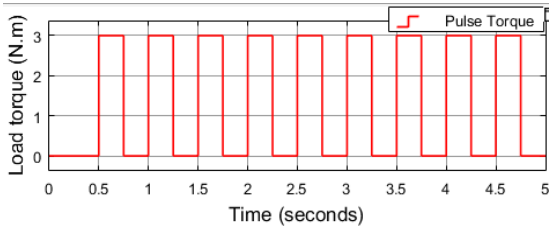

Fig. 10: Pulse load torque: amplitude 3 (N.m), period 0.5 s, pulse width 50%.

out current sensors is effective in controlling the IM drives. The speed of IMs can be maintained stably even with the load torque varying continuously periodic.

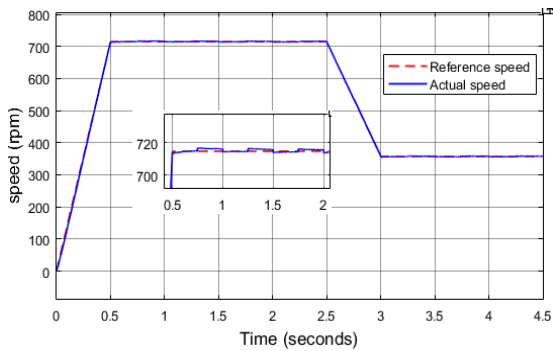

Fig. 11: Reference speed at 50%-25% rating speed: HPWM technique without current sensors at pulse load torque.

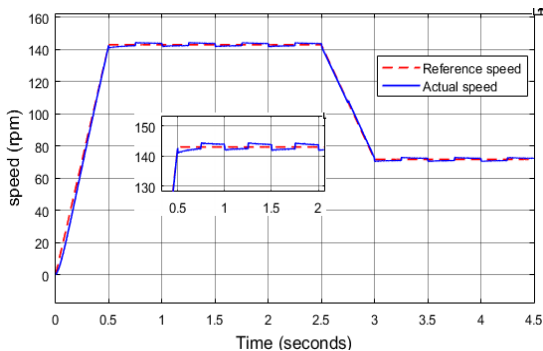

Fig. 12: Reference speed at 10%-5% rating speed: HPWM technique without current sensors at pulse load torque.

The high ripple of currents is the disadvantage of HPWM. The ripple can reduce if the hysteresis band is adjusted to a smaller value, however, the inverter switching loss will increase. Thus,

the hysteresis band should be set at a suitable value to satisfy both control characteristic of IM and power loss of the drive system.

4. CONCLUSION

The paper has proposed a new HPWM technique without current sensors in the speed control of IM drive where the feedback signal from the current sensors was replaced by the estimated currents determined by the hysteresis tolerance values around the reference current value. The simulation results have demonstrated the effectiveness of the proposed method to maintain the speed of IM drive systems in various operating conditions, under load and no load torques, as well as normal speed and low-speed ranges. Due to the parameters of IM can affect the accuracy of the controlling algorithm, especially stator resistance, so the next time, we can focus on increasing the accuracy of stator resistance in the low-speed range.

ACKNOWLEDGEMENT

This research is funded by Graduate Scholarship for Master and Doctoral Programs of Ton Duc Thang University, website: <http://grad.tdtu.edu.vn>.

The paper was supported by the Project reg. no. SP2018/162 - Student Grant Competition of VSB-Technical University of Ostrava, Research and development of advanced control methods of electrical controlled drives, member of research team, 2018.

References

- [1] Vas. P, *Sensorless vector and direct torque control*, Oxford Univ, Press (1998).
- [2] Kohlrusz. G, & Fodor. D, "Comparison of scalar and vector control strategies of induction motors," *Hungarian Journal of Industry and Chemistry*, 39(2), 265-270, 2011.
- [3] Brandstetter. P, "Electrical Drive III," Ostrava Univ, 2014.

- [4] Gaeid. K. S, Ping. H. W, "Fault tolerant control of induction motor," *Modern Applied Science*, 5(4), 83, 2011.
- [5] Baghli. L, Poure. P, Rezzoug. A, "Sensor fault detection for fault tolerant vector controlled induction machine," In *Power Electronics and Applications, 2005 European Conference on (pp. 10-pp)*. IEEE (2005).
- [6] Yu. Y, Zhao. Y, Wang. B, Huang. X, Xu. D, "Current sensor fault diagnosis and tolerant control for VSI-based induction motor drives," *IEEE Transactions on Power Electronics*, 33(5), 4238-4248, 2018.
- [7] Najafabadi. T. A, Salmasi. F. R, Jabejdar-Maralani. P, "Detection and isolation of speed-, DC-link voltage-, and current-sensor faults based on an adaptive observer in induction-motor drives," *IEEE Transactions on Industrial Electronics*, 58(5), pp. 1662-1672. (2011).
- [8] Barba. G, Glielmo. L, Perna. V, & Vasca. F, "Current sensorless induction motor observer and control for hybrid electric vehicles," In *Power Electronics Specialists Conference, 2001. PESC. 2001 IEEE 32nd Annual (Vol. 2, pp. 1224-1229)*. IEEE, 2001.
- [9] Vijayan. N. G, & Prabha. D. M. S. R, "A fault tolerant reconfiguration technique for Indirect Field Oriented Control of Induction Motor drive without using Current sensors," In *Control, Instrumentation, Communication and Computational Technologies (ICCICCT), 2015 International Conference on (pp. 825-828)*. IEEE, 2015.
- [10] Bierhoff. M, & Göllner M, "A current sensor less speed control algorithm for induction motors," In *Industrial Electronics Society, IECON 2016-42nd Annual Conference of the IEEE (pp. 2606-2611)*. IEEE, 2016.
- [11] Tran. D. C, Brandstetter. P, Ho. D. S, Tran. C. T, Nguyen. H. C. M, Phan. X. H, and Dinh. H. B: "Improving Fault Tolerant Control to the one current sensor failures for induction motor drives," in *International Conference on Advanced Engineering Theory and Applications (2018)*. In press.
- [12] Ebenezer. V, Gopakumar. K, & Ranganathan. V. T, "A sensorless vector control scheme for induction motors using a space phasor based current hysteresis controller," *EPE Journal*, 9(3-4), 41-46, 2000.
- [13] Purnata. H, Rameli. M, & Effendie. A. R, "Speed control of three phase induction motor using method hysteresis space vector pulse width modulation," In *Intelligent Technology and Its Applications (ISITIA), 2017 International Seminar on (pp. 199-204)*. IEEE, 2017.
- [14] Haq. H, Imran. M. H, Okumus. H. I, & Habibullah. M, "Speed Control of Induction Motor using FOC Method," *Int. Journal of Engineering Research and Applications*, 5(3), 154-158, 2015.

About Authors

Cuong Dinh TRAN was born in Ho Chi Minh, Vietnam. He graduated from the University of Technology, Ho Chi Minh City, Viet Nam. He received her B.E. and M.E. degrees in electrical-electronics power engineering in 2005 and 2008, respectively. Now, he is teaching at the department of electrical and electronics engineering, Ton Duc Thang University, Ho Chi Minh city, Vietnam. His research interests include modern control methods of electrical drives, automatic control system, intelligent control system, operation and control power system.

Pavel BRANDSTETTER was born in Ostrava, Czech Republic, 1955, 1 June. He received the M.Sc. and Ph.D. degrees in Electrical Engineering from Brno University of Technology, Czech Republic, in 1979 and 1987, respectively. He is currently full professor in Electrical Machines, Apparatus and Drives and dean of Faculty of Electrical Engineering and Computer Science at VSBTechnical University of Ostrava. His current research interests are applied electronics and modern control methods of electrical drives. Since 2000 he has performed research in field of modern control methods for AC motors, for example sensorless control,

applications of artificial intelligence in control of AC drives.

Bach Hoang DINH received Ph.D degree in Electrical Engineering from Heriot-Watt University, Edinburgh, United Kingdom in 2009. He received the B.E. and the M.E. degrees in Electrical Engineering from Vietnam National University - Hochiminh City in 1995 and 1998, respectively. Bach Dinh is currently the head of Electrical Engineering Department, Faculty of Electrical-Electronic Engineering at Ton Duc Thang University. His research interests are intelligent and optimal control, computer vision, robotics, power electronics, SCADA and industrial communication networks. He is a member of the IEEE Industrial Electronics Society.

Sang Dang HO received his B.Eng. and M.Eng degrees in Electrical Engineering from Ho Chi Minh University of Technology, Ho Chi Minh city, Vietnam in 2001 and 2008, respectively. Now, he is teaching at department of electrical and electronics engineering, Ton Duc Thang university, Ho Chi Minh city, Vietnam. His research interests include optimization of power system and electric machines control.

Minh Chau Huu NGUYEN was born in Binh Duong, Vietnam. He graduated from the Military Technical Academy, Vietnam. He received his M.E. degrees in Automation engineering in 2012. Now, he is researching at the Faculty of Electrical Engineering & Computer Science, VSB – Technical University of Ostrava, Czech Republic. His research interests include an automatic control system, intelligent control system and electrical machine, apparatus and drives.

"This is an Open Access article distributed under the terms of the [Creative Commons Attribution License](https://creativecommons.org/licenses/by/4.0/), which permits unrestricted use, distribution, and reproduction in any medium, provided the original work is properly cited (CC BY 4.0)."